

## NEONS

Neon lamps are very rugged and not affected by vibration, mechanical shock, or frequent ON/OFF operation. Neon lamps may be operated over a wide temperature range from -40 to +150°C and are not damaged by voltage transients of high voltage static discharges.

Neon lamps have a special operating characteristic that also allow them to be used as moderately stable, high voltage reference voltage sources. When driven with DC voltage at their design current the voltage across the lamp is stable at a value near 90 Volts.

Neon lamps gradually decline in light output as electrodes evaporate and condense on the inside of the glass envelope. This situation is gradual with failure defined as a 50% decrease from the original brightness. As neon lamps age, the firing voltages slowly increase until reaching the value of the supply voltage. At this point the lamp flickers and becomes erratic, indicating the end of useful lifetime.

Life expectancy of a neon lamp increases considerably as operating current is decreased. For high brightness lamps, there is a 4 to 5 power inverse relationship between current and life, whereas for standard brightness types, the lamp life varies inversely as the 3.5 power of the current. With light output exponentially proportional to current, large increases in rated life can be obtained with small reductions in current and only a small reduction in brightness. For neon lamp applications requiring life ratings of more than 50,000 hours the use of a higher value resistor will reduce lamp current and achieve longer life.

For DC operation, the life of a high brightness lamp is about 50% of a neon lamp operating at the same RMS AC voltage. The life of a standard brightness lamp at DC is about 60% of the life value at AC.

Typical light output color for clear glass neon lamps is in the orange-red range of 600 to 700 nanometers. Other emitted colors such as green, yellow and blue are available through secondary emission by coating the inside surface of the envelope with phosphor.

### ***Neon Terminology***

***Striking Voltage:*** The voltage at which the neon lamp ignites is usually between 45 and 65VAC for standard brightness types and between 70 and 95VAC for high brightness types. This is sometimes called the breakdown or ignition voltage.

***Maintaining Voltage:*** The voltage across the lamp after it has ignited. This voltage is a function of the lamp current and is usually quoted at the design current. Nominal values are 80V for standard brightness and 75V for high brightness lamps.

***Extinction Voltage:*** The voltage at which the lamp extinguishes if the supply voltage is reduced. It is normally a few Volts below maintaining voltage.

***Design Current:*** The current at which the lamp has been designed to operate. It will be determined by the supply voltage and the value of series resistance. Operation at lower currents will result in the glow discharge becoming unstable (i.e. flickering) and operation at higher currents can severely reduce the useful life of the lamp. It is therefore important to use only the recommended value of series resistance.

Neon Lamps 22-25 >

# NEONS

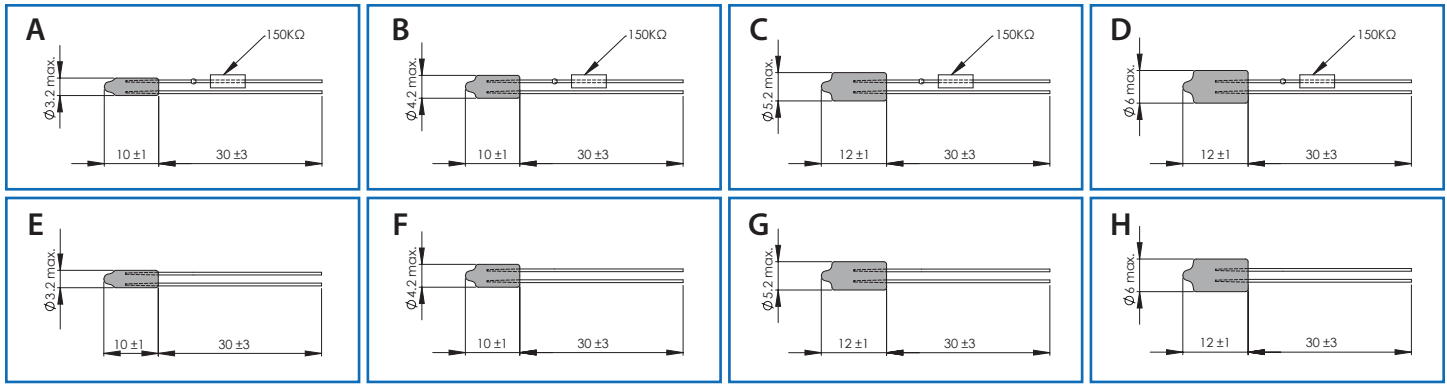

Note: All dimensions are in mm

## Neon Glow Lamps (Standard Brightness)

Line No.	Part No.	Color Off	Color On	Circuit Voltage	Breakdown V		Current mA	Series Resistor		Average Life (hours)	mcd	Drawing
					Maximum AC	DC		115V	220V			
1	N513	Clear	Red	90-115/220	65	90	0.3	150kΩ	480kΩ	30,000	1.4	A
2	N515	Clear	Red	90-115/220	65	90	0.3	150kΩ	480kΩ	40,000	1.4	B
3	N516	Clear	Red	90-115/220	65	90	0.3	150kΩ	480kΩ	50,000	1.4	C
4	N526	Clear	Red	90-115/220	65	90	0.3	150kΩ	480kΩ	50,000	1.4	D

## Neon Glow Lamps (High Brightness) with Dark Effect

Line No.	Part No.	Color Off	Color On	Circuit Voltage	Breakdown V		Current mA	Recommended Series Resistor		Average Life (hours)	mcd	Drawing
					Maximum AC	DC		115V	220V			
5	N517	Clear	Red	90-115/220	95	135	1.0	47kΩ	150kΩ	20,000	5.0	E
6	N519	Clear	Red	90-115/220	95	135	1.0	47kΩ	150kΩ	20,000	5.0	F
7	N520A	Clear	Red	90-115/220	95	135	1.0	47kΩ	150kΩ	25,000	5.0	G
8	N522	Clear	Red	90-115/220	95	135	1.0	47kΩ	150kΩ	25,000	5.0	H

## Neon Glow Lamps (Standard Brightness) with Resistor

Line No.	Part No.	Color Off	Color On	Circuit Voltage	Breakdown V		Current mA	Series Resistor		Average Life (hours)	mcd	Drawing
					Maximum AC	DC		115V	220V			
9	N513R1	Clear	Red	90-115	65	90	0.3	150kΩ		30,000	1.4	A
10	N515R1**	Clear	Red	90-115	65	90	0.3	150kΩ		40,000	1.4	B
11	N516R1	Clear	Red	90-115	65	90	0.3	150kΩ		50,000	1.4	C
12	N526R1**	Clear	Red	90-115	65	90	0.3	150kΩ		50,000	1.4	D

[Click on Part Number to Go to That Item in Online Store](#)

\*\* = Special Order - Please Contact ILT Sales

# NEONS

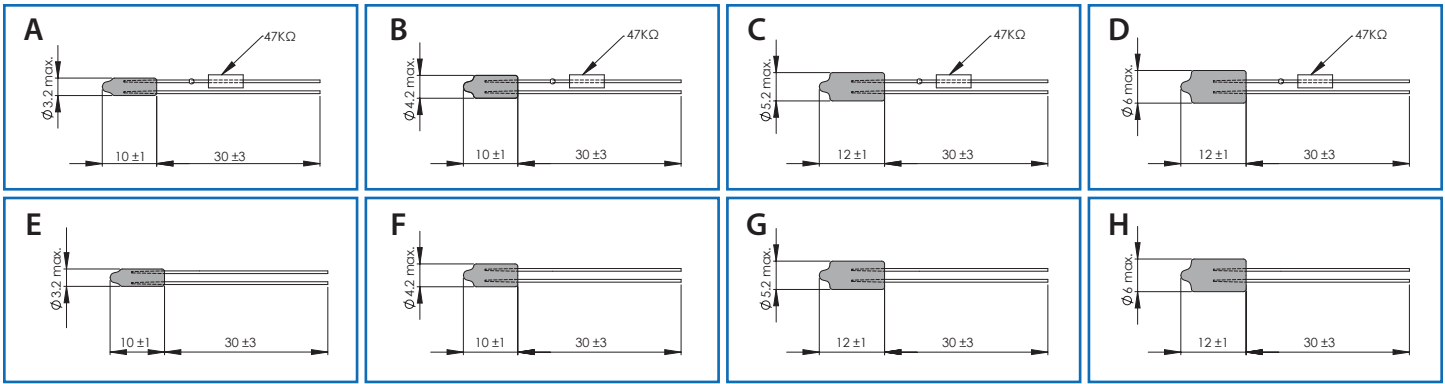

Note: All dimensions are in mm

## Neon Glow Lamps (High Brightness) with Dark Effect & Resistor

Line No.	Part No.	Color Off	Color On	Circuit Voltage	Breakdown V Maximum		Current mA	Series Resistor		Average Life (hours)	mcd	Drawing
					AC	DC		115V	220V			
1	N517R1	Clear	Red	90-115	95	135	1.0	47kΩ		20,000	5.0	A
2	N519R1	Clear	Red	90-115	95	135	1.0	47kΩ		20,000	5.0	B
3	N520R1	Clear	Red	90-115	95	135	1.0	47kΩ		25,000	5.0	C
4	N522R1	Clear	Red	90-115	95	135	1.0	47kΩ		25,000	5.0	D

## Green Glow Lamps

Line No.	Part No.	Color Off	Color On	Circuit Voltage	Breakdown V Maximum		Current mA	Recommended Series Resistor		Average Life (hours)	mcd	Drawing
					AC	DC		115V	220V			
5	N507	White	Green	90-115/220	80	—	0.6	82kΩ	120kΩ	20,000	3.0	E
6	N527	White	Green	90-115/220	85	110	1.2	47kΩ	120kΩ	15,000	3.0	F
7	N521	White	Green	90-115/220	85	110	1.2	47kΩ	120kΩ	15,000	3.0	G
8	N523	White	Green	90-115/220	85	110	1.2	47kΩ	120kΩ	15,000	3.0	H

## Green Glow Lamps with Resistor

Line No.	Part No.	Color Off	Color On	Circuit Voltage	Breakdown V Maximum		Current mA	Series Resistor		Average Life (hours)	mcd	Drawing
					AC	DC		115V	220V			
9	N527R1	White	Green	90-115	85	110	1.2	47kΩ		15,000	3.0	B
10	N521R1**	White	Green	90-115	85	110	1.2	47kΩ		15,000	3.0	C
11	N523R1**	White	Green	90-115	85	110	1.2	47kΩ		15,000	3.0	D

[Click on Part Number to Go to That Item in Online Store](#)

\*\* = Special Order - Please Contact ILT Sales